

## 5. PARAMETRIC FE MODELS AND DESIGN OPTIMISATION

The construction of a complex 3D FE model is not a straightforward task even when using the high-level and powerful programs. The development of a large model may take days, and each modification represents a high investment. In such cases parametric modeling seems to be natural.

Parametric approach permits a finite element model to be defined as a function of variables (parameters) instead of by the more conventional numerical data.

Dimensions can be expressed as named variables or expressions involving other dimensions. If we change a dimension later, the change will be automatically reflected in the entire model. Once the geometric model is ready, finite element meshing is automatic.

With parametric modeling, complete products lines can be analyzed using ONE MODEL.

Now, design studies or routine final product analyses can be completed with significant COST SAVINGS.

### The example: Rectangular plate with the circular hole

#### MODEL CREATION PROCESS

1. First the nominal topology of the object is created by means of ordinary geometric modeling or solid modeling operations. The result is a standard model exhibiting the desired geometric elements and connectivity between elements.
2. Some of the numbers used when building the model are represented by variables (parameters). The relationship between some of the parameters are described in terms of constraints.
3. New models may be created as variants of the basic model by changing the values of the variables. After each change, a new instance of the model is created by re-executing the list of commands being the history of model creation or even the full analysis procedure.

Design optimization is a technique that seeks to determine an optimum design. By one that meets all specified requirements but with a minimum expense of certain factors such as weight, surface :

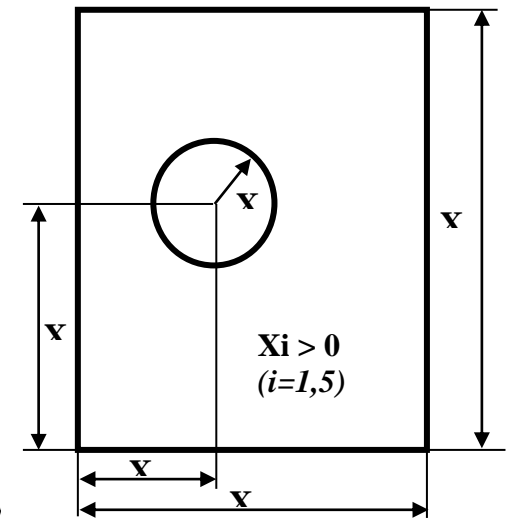

Virtually any aspect of your design can be optimized: dimensions (such as thickness), shape (such as fillet radii), placement of supports, cost of fabrication, natural frequency, material property, and so on. Actually, any item that can be expressed in terms of parameters can be subjected to design optimization.

The ANSYS program offers two optimization methods to accommodate a wide range of optimization problems. The *subproblem approximation* method is an advanced zero-order method that can be efficiently applied to most engineering problems. The *first order* method is based on design sensitivities and is more suitable for problems that require high accuracy.

For both the subproblem approximation and first order methods, the program performs a series of analysis-evaluation-modification cycles. That is, an analysis of the initial design is performed, the results are evaluated against specified design criteria, and the design is modified as necessary. This process is repeated until all specified criteria are met.

The standard optimum design problem formulation

**Minimize the objective function**  $f = f(x)$

*(eg. max. strain energy density, equivalent stress, max. principal strain)*

where

$$x = (x_1, x_2, x_3 \dots x_n)$$

is the vector of design variables *(eg. material data, shape parameters)*

**Constraints:**

$$x_i^* \leq x_i \leq x_i^{**} \quad (i=1,2,\dots,n)$$

$$w_i^* \leq w_i(x) \leq w_i^{**} \quad (i=1,2,\dots,m)$$

## Finite element modelling and optimization techniques

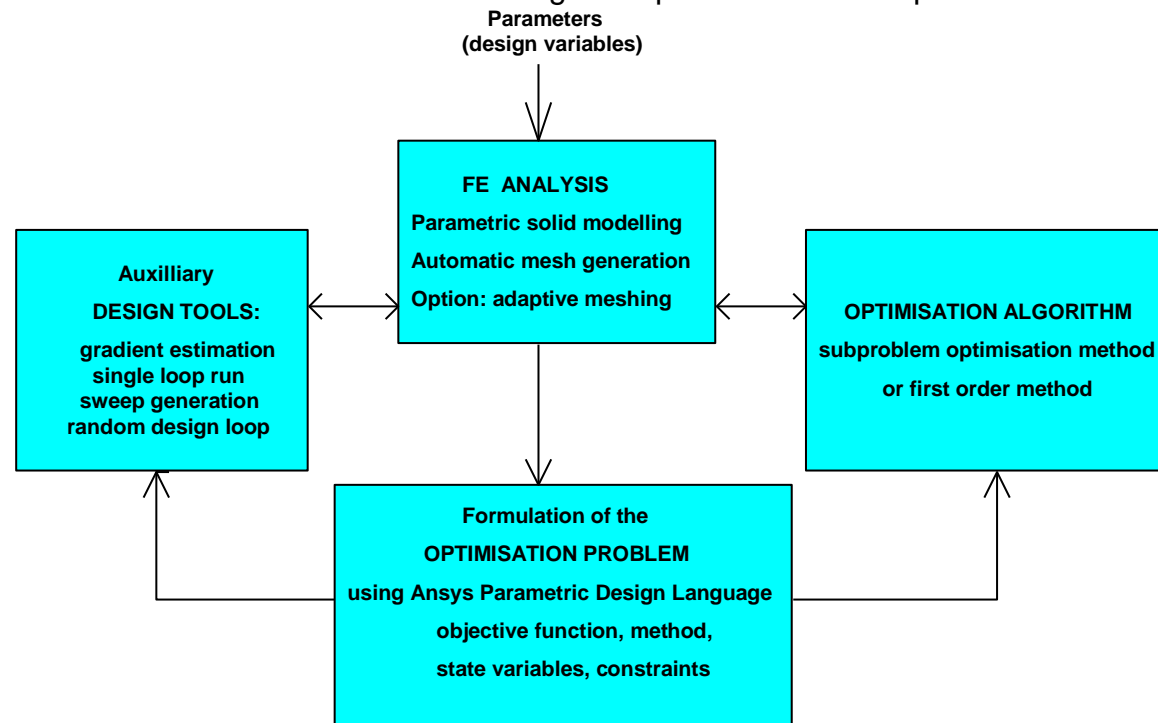

Developing of parametric FE models in mechanical engineering proved to be very useful for comparative analyses and design procedures.

The basic problem in parametric shape modeling is to avoid degeneracies of the solid model and ‘badly shaped’ elements, while performing automatic mesh generation. The important point is also the set of parameters chosen for shape representation.

The basic advantages in parametric approach is significant cost saving when building new variants of the model and easy comparative analyses. The parametric models can be easily used for design optimisation.

Problems in optimization : - convergence

- uniqueness
- constraints
- local or global minimum

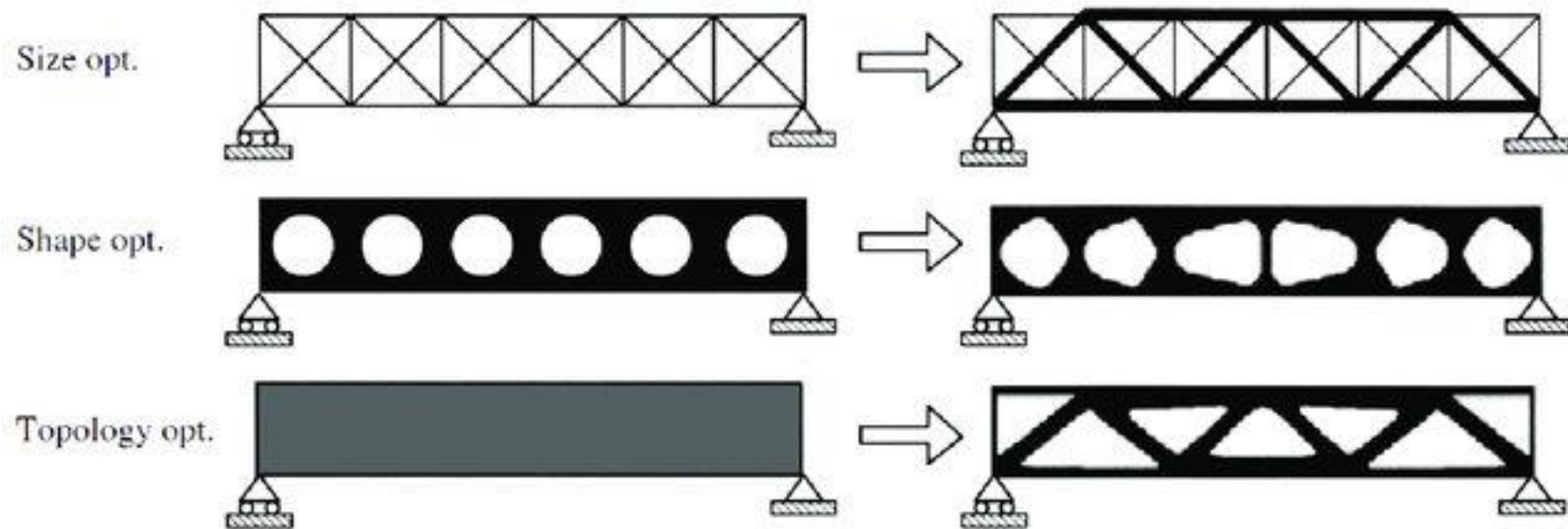

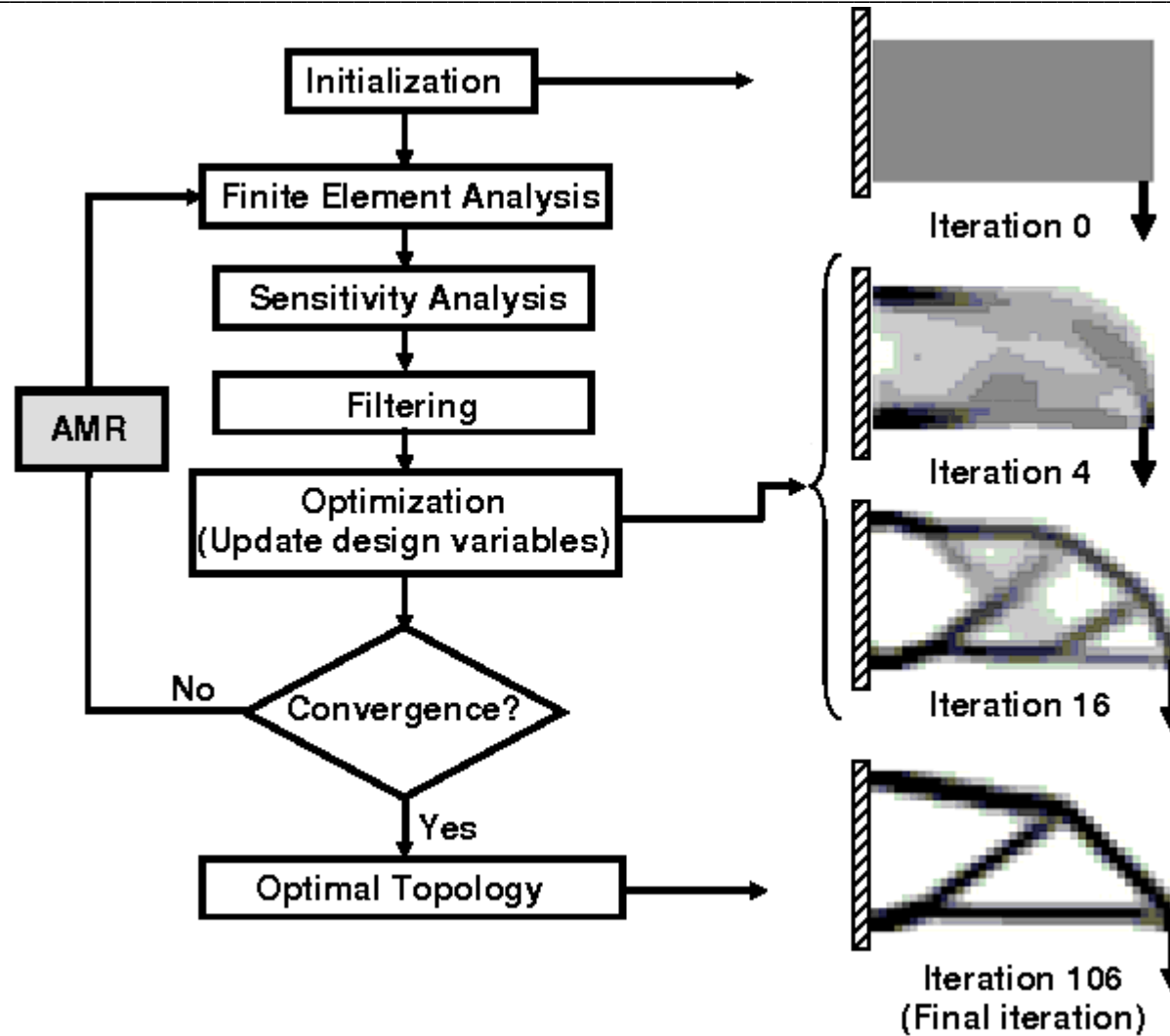

### Topology Optimization

- Placing holes in an original model
  - Use material distribution shades to represent holes
  - Fixed mesh (mesh shape and mesh number does not change)



### Shape Optimization

- Changing shape of the design freely
  - Move nodes in mesh



# Multistage Structural Optimization in the Design of the Lightweight Electrical Vehicle VisioM

Dipl.-Ing. Bernhard Sauerer, Dipl.-Ing. Markus Schatz, Erich Wehrle M.Sc.,  
Prof. Horst Baier

26.06.2014

## 6. FEM IN STRAIN AND STRESS ANALYSIS OF COMPOSITE STRUCTURES

Multilayered laminates with directional fibres have shown their advantages in numerous applications. Due to the highly anisotropic properties of the single plies, laminated composites allow designing of the light structures with properties optimized to given loads/needs.

Composites can fail on the microscopic or macroscopic scale. The failure mechanisms of the composite structures are much more complex than observed in isotropic materials.

The FEM simulations can provide information concerning the stress distributions within the multilayered shell and within the layers. These stress distributions can be used to estimate the strength of the single ply, using the anisotropic strength criteria (Maximum Stress, Maximum Strain, Tsai-Hill, Tsai-Wu, Norris) and also to predict the interface failure.

To get the effective tools for the detailed strength analysis and design of the composite shell structures the multi-scale parametric models may be built going **from the micro to macro scale** (fibres with resin, woven fabric, single layer, multilayered shell element, structure)



### Orthotropic layer of laminated shell structure – analytical description

Stress-strain relation in principal directions

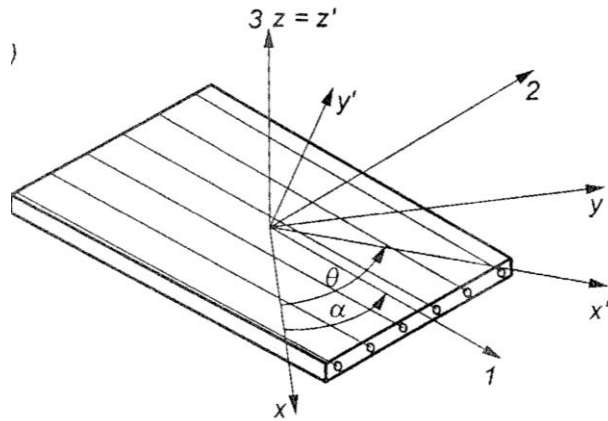

$$\begin{Bmatrix} \sigma_{11} \\ \sigma_{22} \\ \tau_{12} \end{Bmatrix} = \begin{bmatrix} \frac{E_{11}}{1-\nu_{12}\nu_{21}} & \frac{\nu_{12}E_{22}}{1-\nu_{12}\nu_{21}} & 0 \\ \frac{\nu_{21}E_{11}}{1-\nu_{12}\nu_{21}} & \frac{E_{22}}{1-\nu_{12}\nu_{21}} & 0 \\ 0 & 0 & G_{12} \end{bmatrix} \begin{Bmatrix} \varepsilon_{11} \\ \varepsilon_{22} \\ \gamma_{12} \end{Bmatrix}$$

Transformation of stress state components

$$\begin{Bmatrix} \sigma_{x'x'} \\ \sigma_{y'y'} \\ \tau_{x'y'} \end{Bmatrix} = [T] \begin{Bmatrix} \sigma_{xx} \\ \sigma_{yy} \\ \tau_{xy} \end{Bmatrix} \quad [T] = \begin{bmatrix} \cos^2 \theta & \sin^2 \theta & 2\sin \theta \cos \theta \\ \sin^2 \theta & \cos^2 \theta & -2\sin \theta \cos \theta \\ -\sin \theta \cos \theta & \sin \theta \cos \theta & \cos^2 \theta - \sin^2 \theta \end{bmatrix}$$

Hooke's law in arbitrary cartesian coordinate system

$$\begin{Bmatrix} \sigma_{xx} \\ \sigma_{yy} \\ \tau_{xy} \end{Bmatrix} = \begin{bmatrix} Q_{11}^* & Q_{12}^* & Q_{16}^* \\ Q_{12}^* & Q_{22}^* & Q_{26}^* \\ Q_{16}^* & Q_{26}^* & Q_{66}^* \end{bmatrix} \begin{Bmatrix} \varepsilon_{xx} \\ \varepsilon_{yy} \\ \gamma_{xy} \end{Bmatrix}$$

$$\begin{aligned} Q_{11}^* &= Q_{11}c^4 + (Q_{12} + 2Q_{66})s^2c^2 + Q_{22}s^4, \\ Q_{12}^* &= Q_{12}c^4 + (Q_{11} + Q_{22} - 4Q_{66})s^2c^2 + Q_{12}s^4, \\ Q_{22}^* &= Q_{22}c^4 + 2(Q_{12} + 2Q_{66})s^2c^2 + Q_{11}s^4, \\ Q_{66}^* &= Q_{66}c^4 + (Q_{11} + Q_{22} - 2Q_{12} - 2Q_{66})s^2c^2 + Q_{66}s^4, \\ Q_{16}^* &= (Q_{11} - Q_{12} - 2Q_{66})sc^3 - (Q_{12} - Q_{22} - 2Q_{66})s^3c, \\ Q_{26}^* &= (Q_{12} + Q_{22} + 2Q_{66})sc^3 - (Q_{11} + Q_{12} - 2Q_{66})s^3c, \end{aligned}$$

where  $s = \sin \alpha$ ,  $c = \cos \alpha$ , and  $Q_{ij}$  are:

$$Q_{11} = \frac{E_{11}}{1-\nu_{12}\nu_{21}}, \quad Q_{12} = \frac{\nu_{12}E_{22}}{1-\nu_{12}\nu_{21}}, \quad Q_{22} = \frac{E_{22}}{1-\nu_{12}\nu_{21}}, \quad Q_{66} = G_{12}.$$

### Multilayered shell

Simple analytical approach

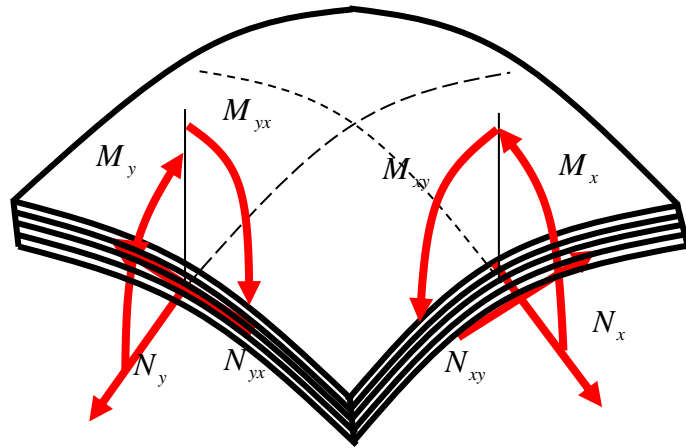

The strain components vector in theory of laminates:

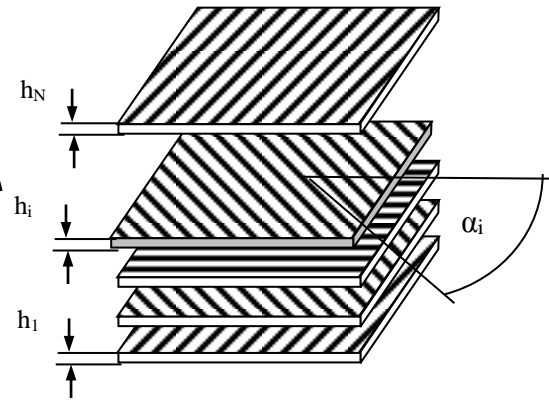

$$\begin{bmatrix} \epsilon_x^0 \\ \epsilon_y^0 \\ \gamma_{xy}^0 \\ \kappa_x \\ \kappa_y \\ \kappa_{xy} \end{bmatrix} = \begin{bmatrix} \mathbf{A} & \mathbf{B} \\ \mathbf{B} & \mathbf{D} \end{bmatrix}^{-1} \begin{bmatrix} N_x \\ N_y \\ N_{xy} \\ M_x \\ M_y \\ M_{xy} \end{bmatrix}$$

Forces and moments acting on the shell segment

where:  $\epsilon_x^0, \epsilon_y^0, \gamma_{xy}^0$  – strain components of the middle surface,

$\kappa_x = -\frac{\partial^2 w_0}{\partial x^2}, \kappa_y = -\frac{\partial^2 w_0}{\partial y^2}, \kappa_{xy} = -\frac{\partial^2 w_0}{\partial x \partial y}$  – curvatures of the middle surface,

$w_0$  – displacements normal to the middle surface,

$\mathbf{A}, \mathbf{B}, \mathbf{D}$  – stiffness matrices:

$$\mathbf{A}_{ij} = \sum_{k=1}^N Q_{ij}^{*k} (z_k - z_{k-1}), \quad \mathbf{B}_{ij} = \frac{1}{2} \sum_{k=1}^N Q_{ij}^k (z_k^2 - z_{k-1}^2), \quad \mathbf{D}_{ij} = \frac{1}{3} \sum_{k=1}^N Q_{ij}^k (z_k^3 - z_{k-1}^3),$$

where:  $z_k$  – distance of the  $k$  layer from the middle surface;

$N$  – numbers of layers;

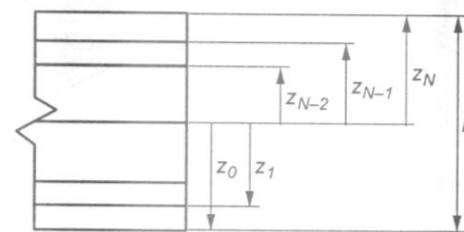

### Example of application of FE analysis to multilayered composite plate

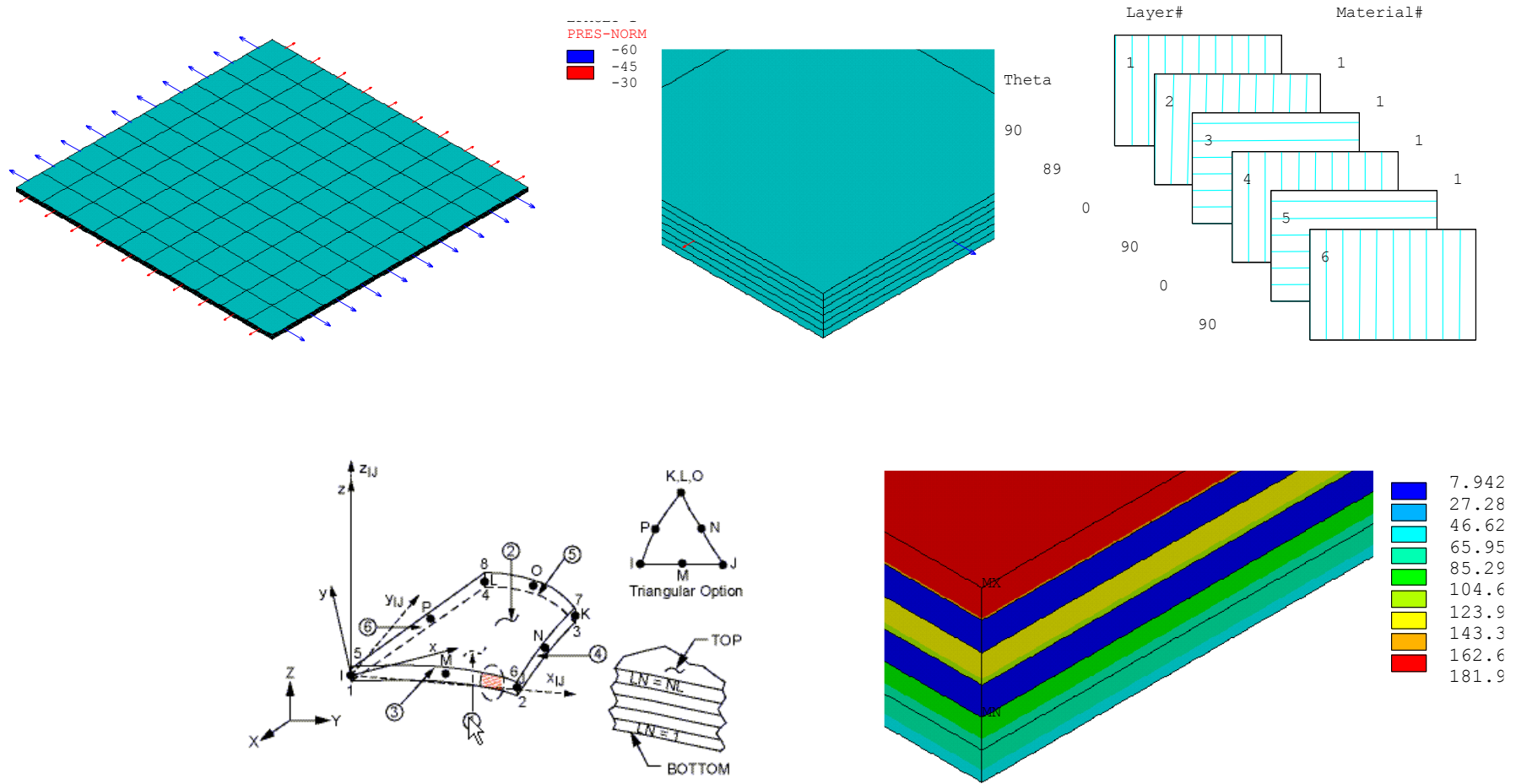

### FE modelling of wooven layer

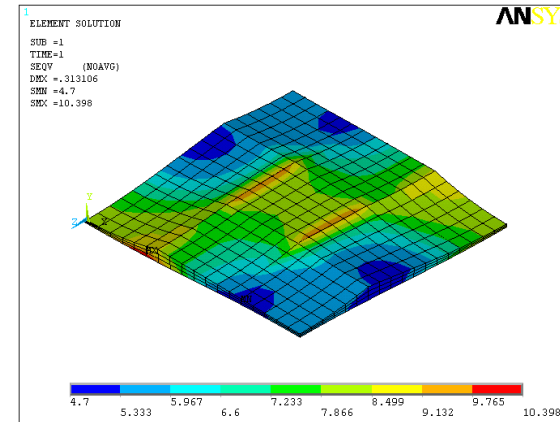
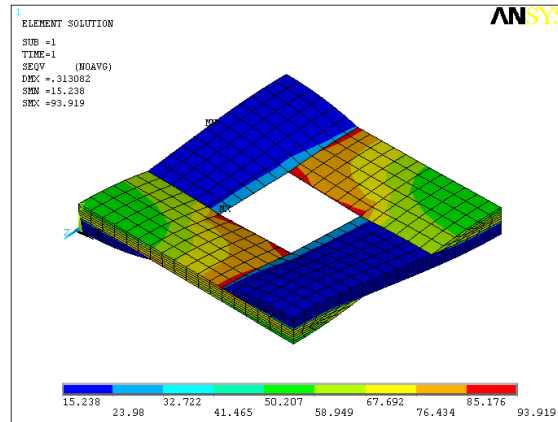
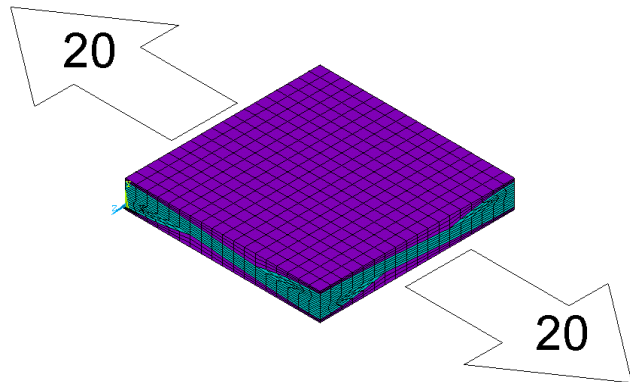
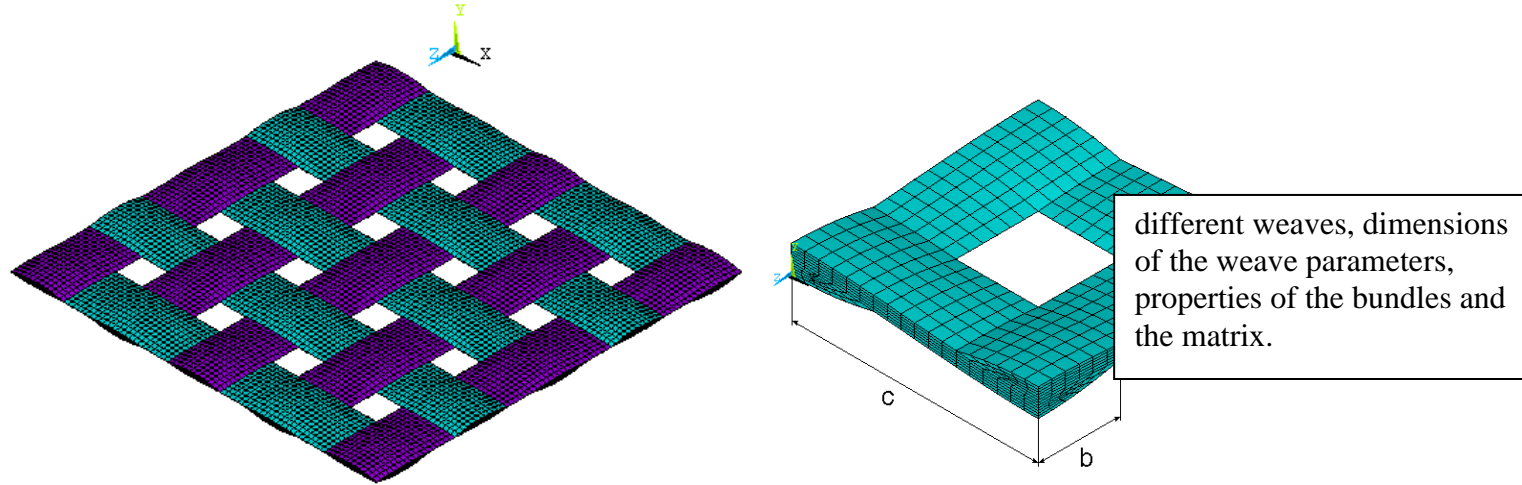

The example of Finite Element Analysis of the composite element of aircraft structure

Stress and strain analysis of the composite wing structure of PW-5 glider

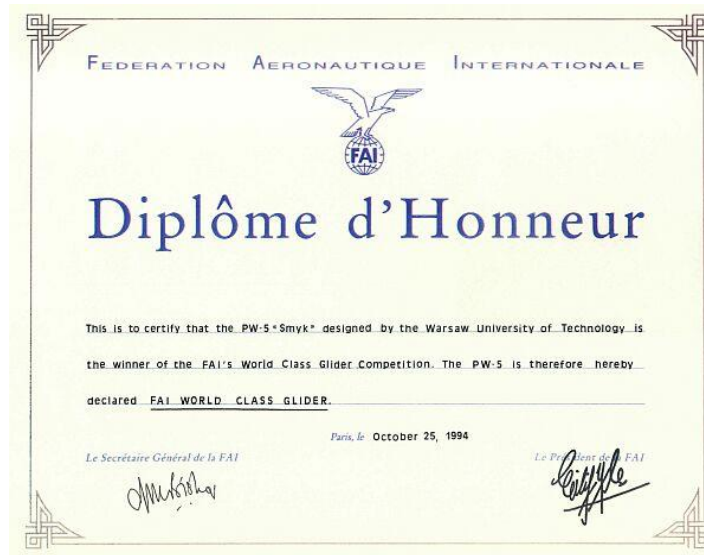
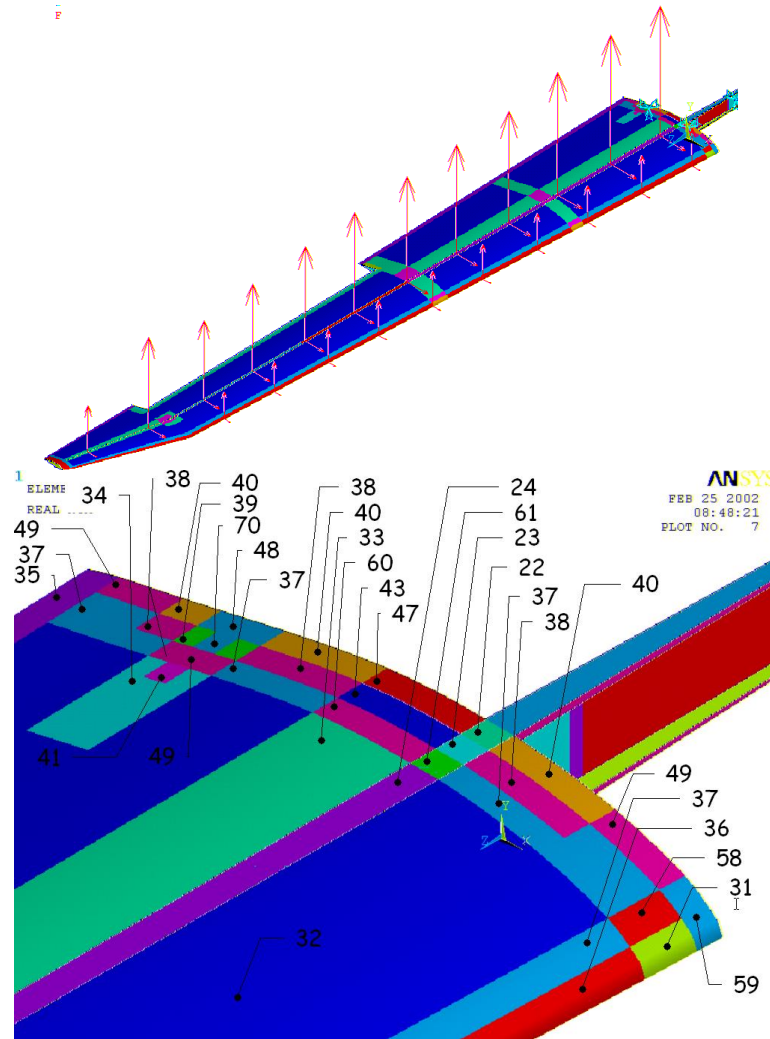

### Deflection of the wing structure under the aerodynamical loads

SMN = -6.328  
SMX = 1438

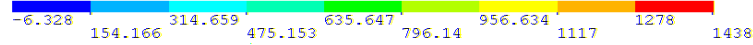
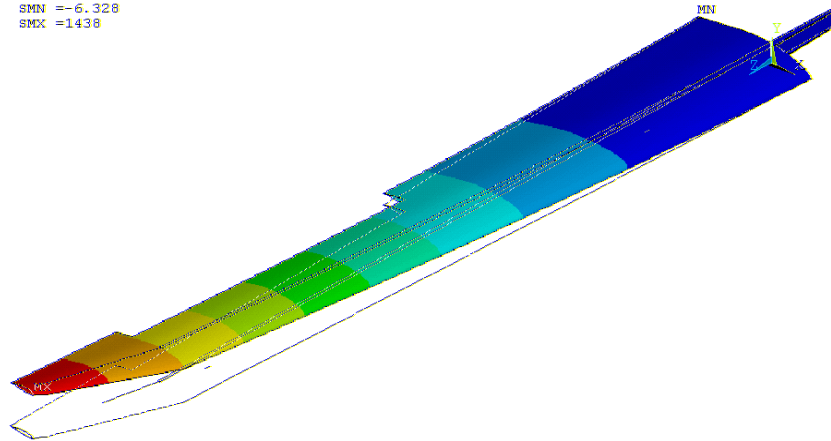

NODAL SOLUTION  
STEP=1  
SUB =1  
TIME=1  
SXZ (AVG)  
DMX =1438  
SMN =-70.244  
SMX =79.172

FEB 25 2002  
10:00:25  
PLOT NO. 1

DMX =1438  
SMN =-278.306  
SMX =277.76

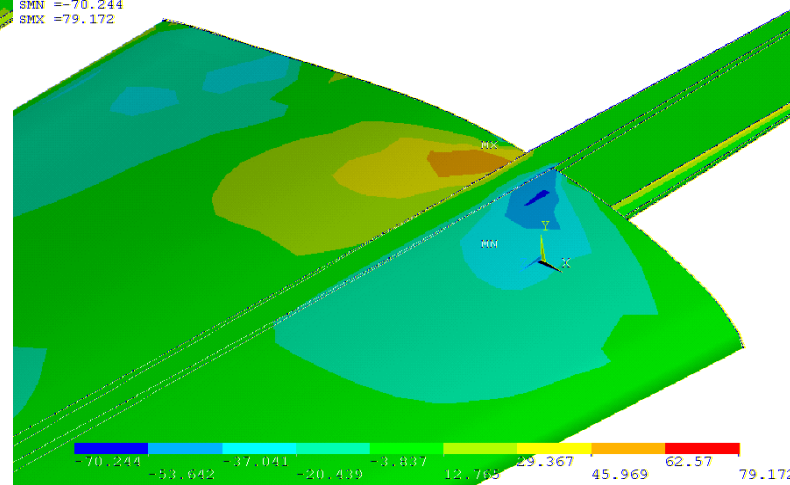
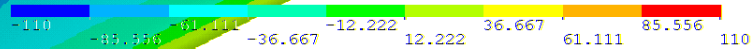
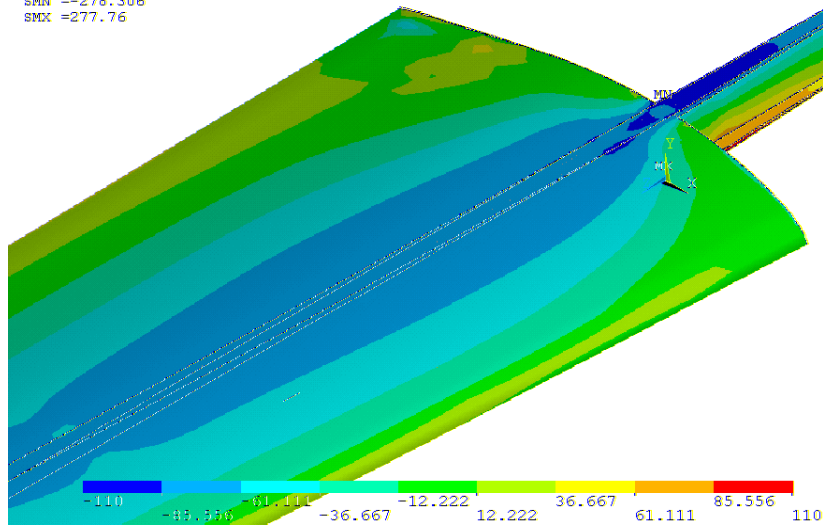

Stress tensor components :  $\sigma_z$  bending stress distribution

and shear stress distribution